

KBMA™**Adjustable Frequency Drives**for 1/8 HP thru 1HP 3-Phase AC Motors
rated 208 – 230 VAC, 50 & 60 Hz**NEMA-1 / IP-40**Operates from 115 and 208/230 Volt 50/60 Hz AC Line
Variable Speed / Soft-Start with Electronic Motor Overload Protection¹**TYPICAL APPLICATIONS**

- Conveyors • Packaging Equipment
- Blowers • HVAC • Door & Gate Openers
- Portable Equipment used with GFCIs⁴



Model KBMA-24D (Part No. 9533) • Model KBMA-24DF (Part No. 9534)

STANDARD FEATURES

- **Simple to Operate:** Does not require programming. Uses trimpots and jumpers, which are factory set for most applications.
- **Motor Horsepower Selection Jumper:** Allows the drive to be used on a wide range of motor horsepower (1/8, 1/4, 1/2, 3/4, 1 HP) without recalibration or programming.
- **Diagnostic LEDs:** PC board mounted LEDs for Power On (ON), Drive Status (ST), and Overload (OL).
- **Run/Fault Relay Output Contacts:** Can be used to turn on or off equipment or to signal a warning if the drive is put into the Stop Mode or a fault has occurred.
- **Barrier Terminal Blocks:** Facilitate wiring of AC line, motor, ground (earth), and Run/Fault Relay Output Contacts.
- **On/Off AC Line Switch:** Panel mounted. Used to turn the power on or off to the drive.
- **Pilot Light:** Panel mounted. Indicates that power is applied to the drive.
- **Main Speed Potentiometer:** Panel mounted. Provides adjustment of motor speed.
- **Jumper Selection of Drive Output Frequency:** Increases the motor speed up to two times the rated RPM.
- **Compatible with GFCIs (with optional software).**

PERFORMANCE FEATURES

- **Power Start™:** Provides more than 200% starting torque which ensures startup of high frictional loads.
- **Slip Compensation with Static Auto-Tune and Boost:** Provides excellent load regulation over a wide speed range.
- **Speed Range:** 60:1

PROTECTION FEATURES

- **Motor Overload (I²t) with RMS Current Limit:** Provides motor overload protection which prevents motor burnout and eliminates nuisance trips.¹
- **Electronic Inrush Current Limit (EICL™):** Eliminates harmful inrush AC line current during startup.
- **Short Circuit:** Shuts down the drive if a short circuit occurs at the motor (phase-to-phase).
- **Regeneration:** Eliminates tripping due to bus overvoltage caused by rapid deceleration of high inertial loads.
- **Overvoltage and Undervoltage:** Shuts down the drive if the AC line input voltage goes above or below the operating range.
- **MOV input transient suppression.**
- **Microcontroller self monitoring and auto-reboot.**

TRIMPOT ADJUSTMENTS

- Minimum Speed (MIN) • Maximum Speed (MAX) • Acceleration (ACCEL)
- Deceleration (DECEL) • Slip Compensation (COMP) • Current Limit (CL)

DESCRIPTION

The KBMA Series Adjustable Frequency Drives are variable speed controls housed in a NEMA-1/IP-40 enclosure. They are designed to operate 208 – 230 Volt 50 & 60 Hz 3-phase AC induction motors from 1/8 HP thru 1 HP. The sine wave coded Pulse Width Modulated (PWM) output operates at a carrier frequency of 16 kHz, which provides high motor efficiency and low noise. Adjustable Linear Acceleration and Deceleration make the drive suitable for soft-start applications. The Motor Horsepower Selection Jumper allows the drive to be used on a wide range of motor horsepower (1/8, 1/4, 1/2, 3/4, 1 HP) without recalibration or programming. Model KBMA-24DF contains a built-in AC line Class A RFI (EMI) filter which meets the CE Council Directive 89/336/EEC Industrial Requirement.

Its user-friendly design makes the KBMA easy to install and operate. Setting the drive to specific applications is accomplished with selectable jumpers and trimpots, which eliminates the computer-like programming required on other drives. However, for most applications no adjustments are necessary. For more advanced programming, PC based Drive-Link™ software is available.

Main features include adjustable RMS Current Limit and I²t Motor Overload Protection.¹ In addition, Adjustable Slip Compensation with Static Auto-Tune and Boost provides high torque and excellent load regulation over a wide speed range. Power Start™ delivers over 200% motor torque to ensure startup of high frictional loads. Electronic Inrush Current Limit (EICL™) eliminates harmful AC line inrush current. A Run/Fault Relay is provided, which can be used to turn on or off equipment or to signal a warning if the drive is put into the Stop Mode or a fault has occurred.

Standard front panel features include an On/Off AC Line Switch, a Pilot Light for power on, and a Main Speed Potentiometer. Other features include PC board mounted diagnostic LEDs (Power On (ON), Drive Status (ST) and Overload (OL)), Barrier Terminal Blocks to facilitate wiring (AC line, motor, ground (earth), and Run/Fault Relay Output Contacts), adjustable trimpots (MIN, MAX, ACCEL, DECEL, COMP, CL), customer selectable jumpers (AC Line Input Voltage Selection, Motor Horsepower, Automatic or Manual Start and Reset⁵, Motor Frequency, Frequency Multiplier, "Run" or "Fault" Output Relay Operation).

Optional accessories include: Forward-Stop-Reverse Switch⁵, AC Line Filter, and Programming Kit.

SELECTABLE JUMPERS

- AC Line Input Voltage Selection (115/230 Volts AC) (J1)
- Motor Horsepower (1/8, 1/4, 1/2, 3/4, 1 HP) (J2)
- Automatic or Manual Start and Reset (J3)
- Frequency Multiplier (1X, 2X) (J4) • Motor Frequency (50/60 Hz) (J5)
- "Run" or "Fault" Output Relay Operation (J6)

Notes: 1. UL approved as an electronic overload protector for motors. 2. Pending. 3. Use Model KBMA-24DF or install CE approved RFI (EMI) Filter. See AC Line Filters, in Optional Accessories. 4. Requires optional software. 5. The optional Forward-Stop-Reverse Switch is required for Manual Start.

GENESIS®

Automation and Control

COPYRIGHT © 2006 KB Electronics, Inc.

TABLE 1 – GENERAL PERFORMANCE SPECIFICATIONS

Description	Specification	Factory Setting
115 Volt AC Line Input Voltage Operating Range (Volts AC) ¹	115 (±15%)	—
208/230 Volt AC Line Input Voltage Operating Range (Volts AC) ¹	208 (-15%) / 230 (+15%) ²	—
Maximum Load (% Current Overload for 1 Minute)	150	—
Horsepower Selection (HP) (J2)	1/8, 1/4, 1/2, 3/4, 1	1
Carrier, Switching Frequency (kHz)	16, 8	—
Output Frequency Resolution (Bits, Hz)	10, .06	—
Minimum Speed Trimpot (MIN) Range (% Frequency Setting)	0 – 40	0
Maximum Speed Trimpot (MAX) Range (% Frequency Setting)	70 – 110	100
Acceleration Trimpot (ACCEL) and Deceleration Trimpot (DECEL) Range (Seconds)	.3 – 20	1.5
Slip Compensation Trimpot (COMP) Range at Drive Rating (Volts/Hz)	0 – 3	1.5
Current Limit Trimpot (CL) Range (% Full Load)	0 – 200	160
Motor Frequency Setting (Hz) (Jumper J5)	50, 60	60
Output Frequency Multiplier (1X, 2X) (Jumper J4) ³	1, 2	1
Minimum Operating Frequency at Motor (Hz)	0.3	—
Speed Range (Ratio)	60:1	—
Speed Regulation (30:1 Speed Range, 0 – Full Load) (% Base Speed) ⁴	2.5	—
Overload Protector Trip Time for Stalled Motor (Seconds)	6	—
Undervoltage/Overvoltage Trip Points for 115 Volt AC Line Input (±5%) (Volts AC) ¹	76 – 141	—
Undervoltage/Overvoltage Trip Points for 208/230 Volt AC Line Input (±5%) (Volts AC) ¹	151 – 282	—
Run/Fault Relay Output Contact Rating (Amps at 30 Volts DC, 125 Volts AC, 250 Volts AC)	1, 0.5, 0.25	—
Operating Temperature Range (°C / °F)	0 – 45 / 32 – 113	—

Notes: 1. Do not operate the drive outside the specified AC line input voltage operating range. 2. The drive is factory set for 208/230 Volt AC line input (Jumper J1 not installed). For 115 Volt AC line input, install Jumper J1 (supplied). See Figure 4, on page 4. 3. Allows the motor to operate up to two times the rated RPM. Constant motor horsepower will result when operating the drive in the "2X" mode above the motor nameplate rated RPM. 4. Dependent on motor performance.

TABLE 2 – ELECTRICAL RATINGS

Model	Part No.	AC Line Input			Fuse or Circuit Breaker Rating (Amps)	Output			Net Weight	
		Volts AC (50/60 Hz)	Phase (φ)	Maximum Current (Amps AC)		Voltage Range (Volts AC)	Maximum Continuous Load Current (RMS Amps/Phase)	Maximum Horsepower (HP (kW))	Lbs.	kg
KBMA-24D	9533	115	1	16	20	0 – 230	3.6	1 (.75)	2.42	1.09
		208/230 ¹	1	10	15					
KBMA-24DF ²	9534	115	1	16	20	0 – 230	3.6	1 (.75)	2.48	1.12
		208/230 ¹	1	10	15					

Notes: 1. The drive is factory set for 208/230 Volt AC line input (J1 not installed). For 115 volt AC line input, install Jumper J1 (supplied). See Figure 4, on page 4. 2. Model KBMA-24DF contains a built-in AC line Class A RFI (EMI) filter which meets the CE Council Directive 89/336/EEC Industrial Requirement.

FIGURE 1 – MECHANICAL SPECIFICATIONS (Inches/mm)

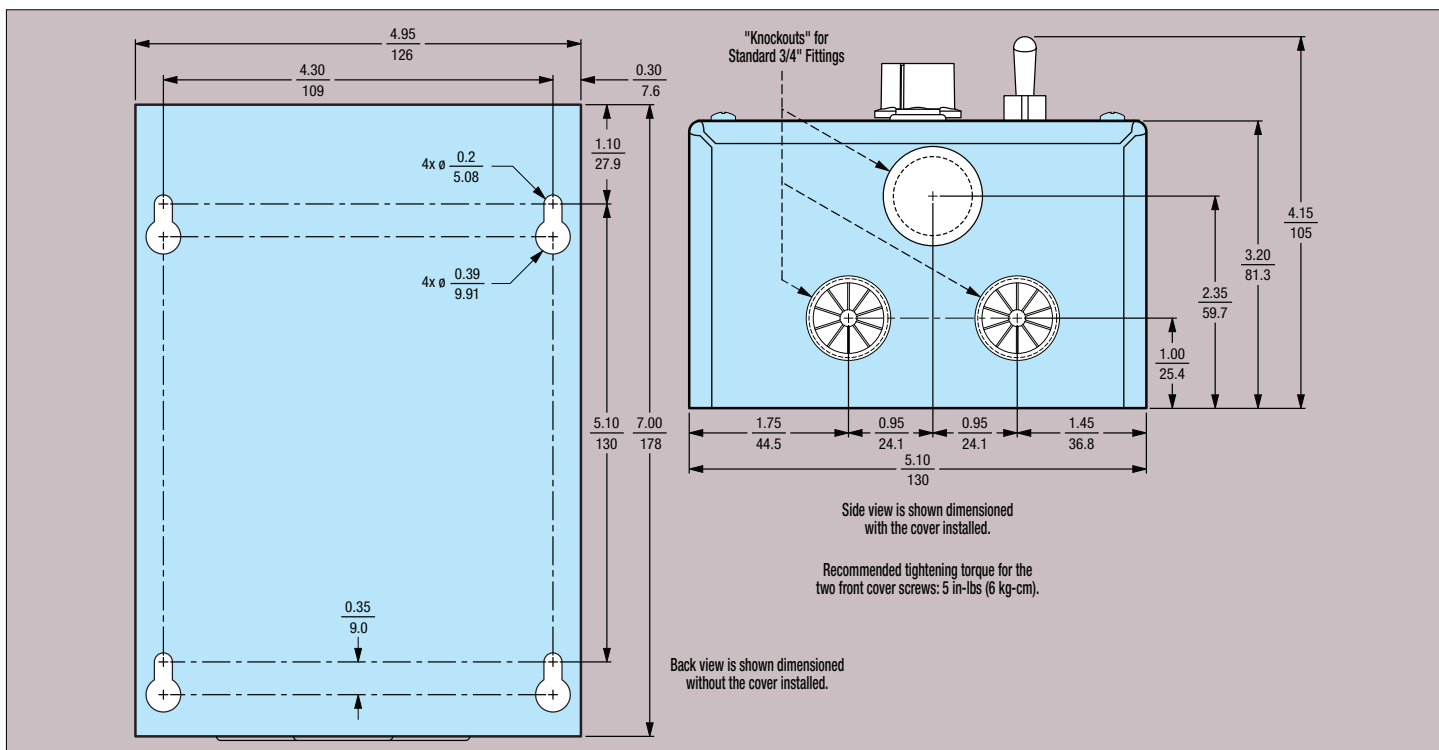

FIGURE 2 – COVER LAYOUT

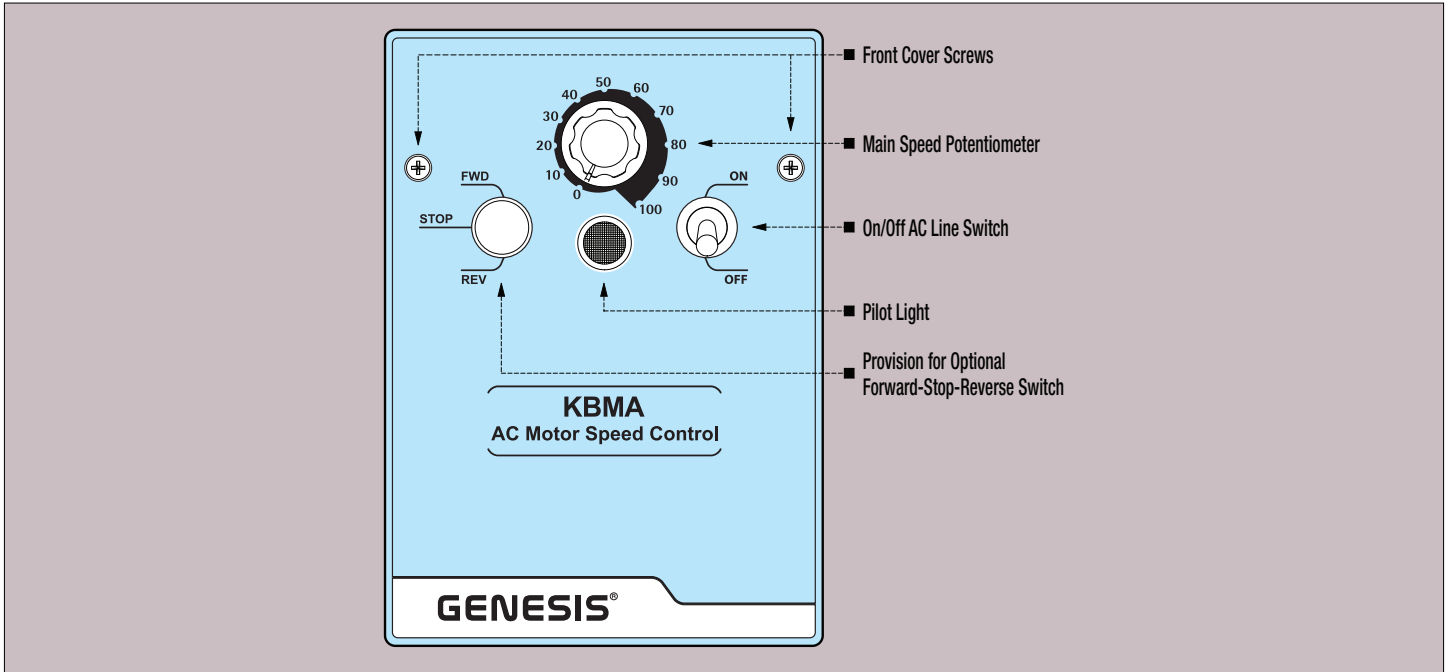

FIGURE 3 – CONTROL LAYOUT

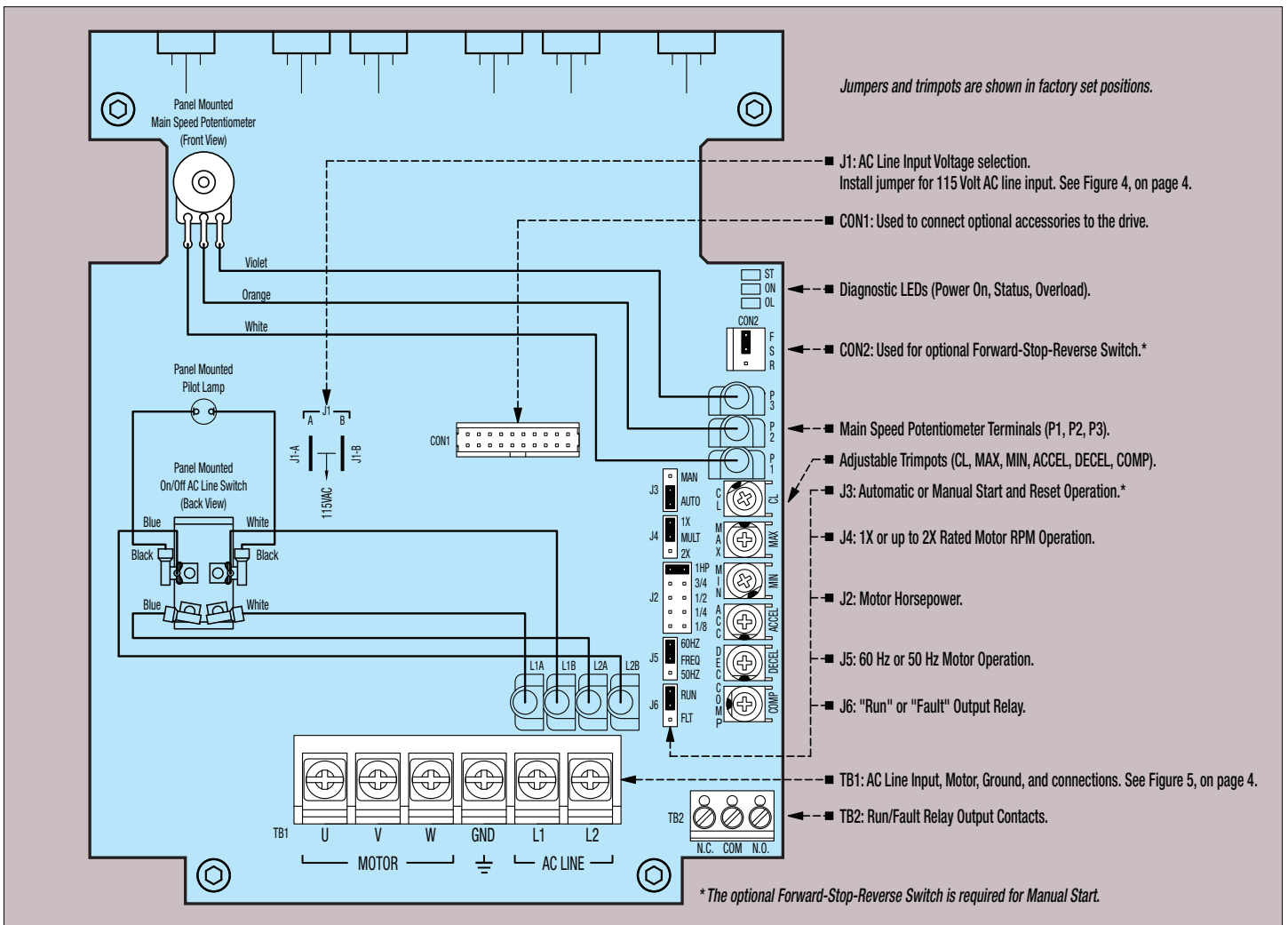
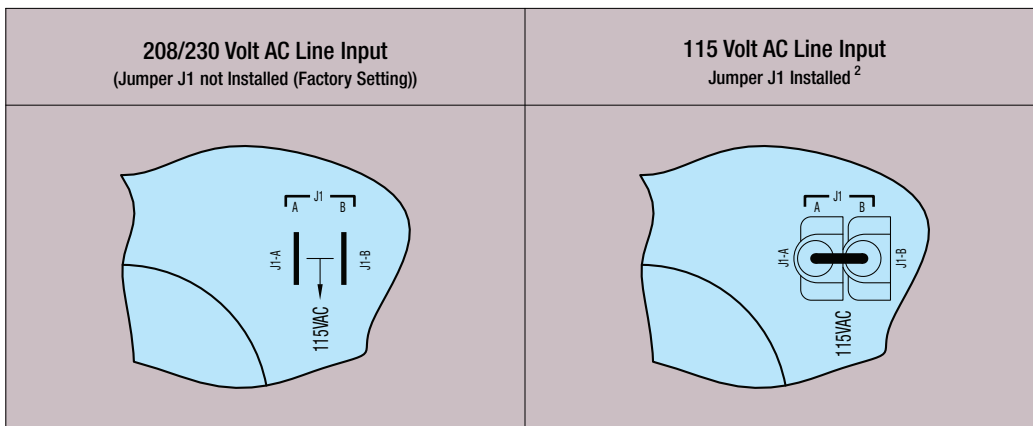

FIGURE 4 – AC LINE INPUT VOLTAGE SELECTION¹



Notes: 1. The drive is factory set for 208/230 Volt AC line input (Jumper J1 not installed). For 115 Volt AC line input, install Jumper J1 (supplied).
 2. Jumper J1 is supplied in the hardware bag.

FIGURE 5 – AC LINE INPUT, MOTOR & GROUND CONNECTIONS

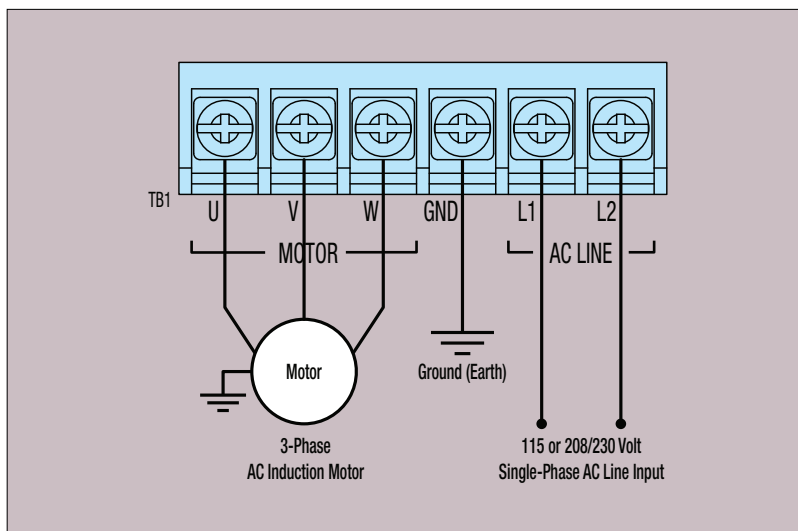

TABLE 3 – OPTIONAL ACCESSORIES

Description	Part No.
Forward-Stop-Reverse Switch: Provides motor reversing, stop, and manual start functions.	9519
KBRF-300: Panel mount. AC line Class B RFI (EMI) filter which meets the CE Council Directive 89/336/EEC Residential Requirement.	9484
Programming Kit: Includes DownLoad Module™ (DLM) handheld programming device which uploads and downloads drive programs, PC to DLM serial communication cable, PC to DLM serial and USB communication cables, DLM to drive communication cable, and PC Windows® based Drive-Link™ communication software. Available for OEM applications only – contact our Sales Department.	9582

